



# A30XTA

## Algorithmic addressable heat sensor



Algorithmic addressable heat sensor for fire detection.

The A30XTA sensor is based on the physical properties of a NTC. The variation of the electrical features of the NTC thermistor due to variation of room temperature makes it suitable for a heat sensor.

The A30XTA is capable of registering absolute temperatures (heat sensor) but also temperature rises (rise of heat rate sensor).

The heat rate function allows detect a fire in the first phases of its growth. If it is very slow, the sensor is activated when temperature reaches 60°C.

Features:

- Low section, total height less than 45 mm (including the base).
- Available with high base for electrical conduit of 20 mm.
- Alarm with two red LED, which makes easier the identification from any direction (360°).
- Possibility to connect a remote action indicator.
- Easy connection, without polarity.
- A single flash of LED indicators shows communication with the control panel, and alarm status with LED on.
- Detector and base with easy installation, interchangeable with the entire of range A30X, and manufactured in white heat-resistant ABS.
- According to EN 54 part 5 class A2R (sensors with heat rise function), and CE mark according to the European Regulation of Construction Products (UE) N°305/2011.

### TECHNICAL FEATURES

Power Supply	24 - 35V without polarity
Standby Current	1 mA
Alarm Current	5 mA
Activation Signal	Two Red LED ( 360° visibility)
Remote Indicator Output	Yes
Humidity	20 - 95% RH
Temperature	-10°C +50°C
Sensitivity	According to EN 54-5 Class A2R
IP Protection	IP 20
Coverage area	56m <sup>2</sup> (subject to local regulation)

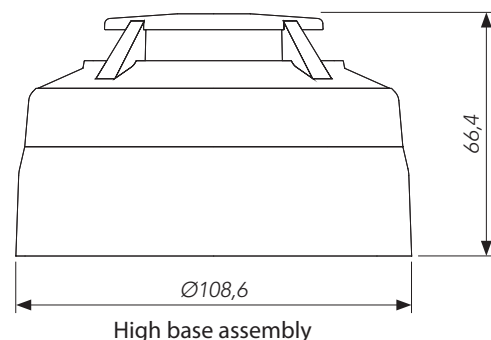

High base assembly



Other colors on request

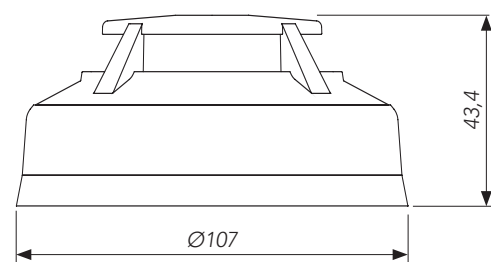

Low base assembly