

DINION IP thermal 8000

www.boschsecurity.com



BOSCH
Invented for life



- ▶ Long detection range (up to 5850 m)
- ▶ Integrated Intelligent Video Analytics
- ▶ 640 x 480 resolution version available for even sharper images
- ▶ High access security for data protection

This thermal IP camera provides high-sensitivity thermal images using an un-cooled vanadium oxide microbolometer that delivers outstanding image quality. The camera is designed to combine the benefits of thermal imaging with the market leading Intelligent Video Analytics from Bosch. There is no need for natural or artificial lighting of the area of interest. The camera produces crisp and clear images day and night, even in challenging environments with smoke, dust, haze or fog.

Versions

The camera comes with a choice of narrow field-of-view (NFOV) or wide field-of-view (WFOV) lenses. The QVGA resolution variant is available with a frame rate of 9 or 60 fps; the VGA resolution variant is available with a frame rate of 9 or 30 fps.

The camera is enclosed in a robust outdoor housing making it ideal for a wide range of applications in demanding environments.

System overview

Range Performance

The following tables give the approximate range performance under ideal conditions of the various lenses for standard monitoring.

7.5 mm lens QVGA FoV: 41.8°H x 30°V	Human*	Object*
Detection	140 m (459 ft)	640 m (2100 ft)
Recognition	35 m (115 ft)	160 m (525 ft)
Identification	18 m (59 ft)	80 m (262 ft)
9 mm lens VGA FoV: 70°H x 52°V	Human	Object
Detection	155 m (509 ft)	700 m (2297 ft)
Recognition	40 m (131 ft)	175 m (574 ft)
Identification	20 m (66 ft)	88 m (289 ft)
16.7 mm lens VGA FoV: 37.5°H x 28°V	Human	Object
Detection	315 m (1033 ft)	1450 m (4757 ft)
Recognition	80 m (262 ft)	360 m (1181 ft)
Identification	40 m (131 ft)	180 m (591 ft)

19 mm lens QVGA FoV: 16°H x 12°V	Human	Object
Detection	380 m (1247 ft)	1750 m (5741 ft)
Recognition	95 m (312 ft)	440 m (1444 ft)
Identification	48 m (157 ft)	220 m (722 ft)

35 mm lens VGA FoV: 17.6°H x 13.2°V	Human	Object
Detection	690 m (2264 ft)	3200 m (10499 ft)
Recognition	170 m (558 ft)	800 m (2625 ft)
Identification	85 m (279 ft)	400 m (1312 ft)

65 mm lens VGA FoV: 9.6°H x 7.2°V	Human	Object
Detection	1270 m (4167 ft)	5850 m (19193 ft)
Recognition	320 m (1050 ft)	1460 m (4790 ft)
Identification	160 m (525 ft)	730 m (2395 ft)

*Human: 1.8 x 0.5 m (5.9 x 1.6 ft); Object: 2.3 x 2.3 m (7.5 x 7.5 ft)

Lens	Focus distance
65 mm*	141 m to ∞
35 mm*	41 m to ∞
19 mm	13.2 m to ∞
16.7 mm	9.0 m to ∞
9 mm	2.4m to ∞
7.5 mm	1.7 m to ∞

*The focus distance of the 35 mm and 65 mm lenses can be adjusted manually in the application, please check the Bosch website to download the guide if required.

Functions

Intelligent Video Analytics

The integrated video analytics is both robust and intelligent. The Intelligence-at-the-Edge concept now delivers even more powerful features:

- Simple calibration
- False alarm reduction
- Extended range identification

The mission critical video analytics reliably detects, tracks, and analyzes objects, and alerts you when predefined alarms are triggered. A smart set of alarm rules, together with object filters and tracking modes, makes complex tasks easy.

The system is also extremely robust and is able to reduce false alarms, for example from foliage or shaking objects, even in harsh weather conditions. Metadata is attached to your video to add sense and structure. This enables you to quickly retrieve the relevant images from hours of stored video. Metadata

can also be used to deliver irrefutable forensic evidence or to optimize business processes based on people counting or crowd density information. Calibration is quick and easy – just enter the height of the camera. The internal gyro/accelerometer sensor provides the rest of the information to precisely calibrate the video analytics.

Bitrate optimized profile

The average typical optimized bitrate in kbits/s for various frame rates is shown in the table:

IPS	VGA	QVGA
60	-	360
30	850	196
15	510	125
9	250	91
3	105	52

Multiple streams

The innovative multi-streaming feature delivers various H.264 streams together with an M-JPEG stream. These streams facilitate bandwidth-efficient viewing and recording as well as integration with third-party video management systems.

The camera can run multiple independent streams that allows to set a different resolution and frame rate on the first and second stream. The user can also choose to use a copy of the first stream.

The third stream uses the I-frames of the first stream for recording; the fourth stream shows a JPEG image at a maximum of 10 Mbit/s.

Storage management

Recording management can be controlled by the Bosch Video Recording Manager (Video Recording Manager) or the camera can use iSCSI targets directly without any recording software.

Edge recording

Insert a memory card into the card slot to store up to 2 TB of local alarm recording. Pre-alarm recording in RAM reduces recording bandwidth on the network, and extends the effective life of the memory card.

Hybrid operation

A surge-protected analog video output allows full hybrid operation. This means that high resolution IP video streaming and an analog video output are available simultaneously. The hybrid functionality offers an easy migration path from legacy CCTV to a modern IP-based system.

Data security

Special measures have been put in place to ensure the highest level of security for device access and data transport. The three-level password protection with security recommendations allows users to customize

device access. Web browser access can be protected using HTTPS and firmware updates can also be protected with authenticated secure uploads. The on-board Trusted Platform Module (TPM) and Public Key Infrastructure (PKI) support, guarantee superior protection from malicious attacks. The 802.1x network authentication with EAP/TLS, supports TLS 1.2 with updated cipher suites including AES 256 encryption.

The advanced certificate handling offers:

- Self-signed unique certificates automatically created when required
- Client and server certificates for authentication
- Client certificates for proof of authenticity
- Certificates with encrypted private keys

Complete viewing software

There are many ways to access the camera’s features: using a web browser, with the Bosch Video Management System, with the free-of-charge Bosch Video Client or Video Security Client, with the video security mobile app, or via third-party software.

System integration

The camera conforms to the ONVIF Profile S specifications. Compliance with these standards guarantees interoperability between network video products regardless of manufacturer. Third-party integrators can easily access the internal feature set of the camera for integration into large projects. Visit the Bosch Integration Partner Program (IPP) website (ipp.boschsecurity.com) for more information.

Certifications and approvals

Standards	Type
Emission	EN 55032: 2012 /AC: 2013 class B FCC: 47 CFR Part 15 B, class B RCM: AS/NZS CISPR 22: 2009 /A1: 2010 VCCI: V2 & V3 /2015.04
Immunity	EN 50130-4: 2011 /A1: 2014 EN 50121-4: 2006 /AC: 2008 EN 55024: 2010 /A1: 2015
Environmental	EN 50130-5:2011 Class IV, Salt mist 28 days passed
Safety	EN 60950-1: 2006 /A11: 2009 /A1: 2010 / A12: 2011 /A2: 2013 EN 60950-22: 2006 /A11: 2008 UL 60950-1, Ed. 2, October 14, 2014 CAN/CSA C22.2 No. 60950-1-07, Ed. 2, October 2014
Marks	cUL, CE, WEEE, RCM, EAC, VCCI, FCC, RoHS

Region	Regulatory compliance/quality marks	
Europe	CE	DINION IP thermal 8000
USA	UL	DINION IP thermal 8000

Installation/configuration notes

Dimensions

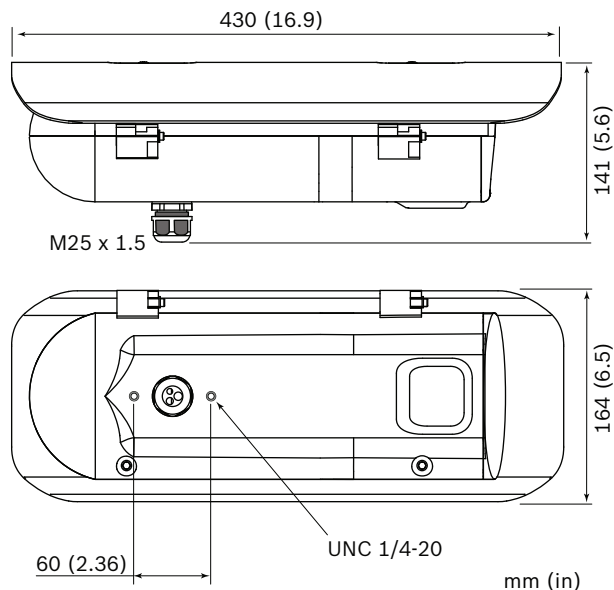

Technical specifications

Power		
Input voltage	24 VAC (SELV) ±10% 50/60 Hz	
Power consumption	34 W max.	
Thermal module		
Image sensor	Un-cooled vanadium oxide microbolometer	
Picture elements	320(H) x 240(V) or 640(H) x 480(V)	
Pixel pitch	17 µm	
Thermal sensitivity	< 50 mK	
Video resolution		
QVGA	320 x 240 at 9 fps or 60 fps	
VGA	640 x 480 at 9 fps or 30 fps	
Video functions – color		
Adjustable picture settings	Contrast	
Thermal color mapping	12 selectable modes	
Lenses FoV (H x V)		
	QVGA	VGA
7.5 mm	41.8° x 30°	-
9 mm	-	70° x 52°
16.7 mm	-	37.5° x 28°

Lenses FoV (H x V)		
19 mm	16° x 12°	-
35 mm	-	17.6° x 13.2°
65 mm	-	9.6° x 7.2°
Video streaming		
Video compression	H.264 (MP); M- JPEG	
Streaming	Multiple configurable streams in H.264 and M-JPEG, configurable frame rate and bandwidth. Regions of Interest (ROI)	
Camera processing latency	<55 ms	
GOP structure	IP, IBP, IBBP	
Camera installation		
Analog output	Off, 4:3, 16:9 pillar box, 16:9 crop	
Positioning	Coordinates / Mounting height	
Video content analysis		
Analysis type	Intelligent Video Analytics	
Configurations	Silent VCA / Profile1/2 / Scheduled / Event triggered	
Alarm rules (combinable)	Any object Object in field Line crossing Enter / leave field Loitering Follow route Counting Occupancy Condition change Similarity search Flow / counter flow	
Object filters	Duration Size Aspect ratio Speed Direction Object classes (4)	
Tracking modes	Standard (2D) tracking Ship tracking Museum mode	
Calibration	Automatic based on gyro / accelerometer data and camera height	
Additional functions		
Video authentication	Off / Watermark / MD5 / SHA-1 / SHA-256	
Display stamping	Name; Logo; Time; Alarm message	
Pixel counter	Selectable area	

Local storage	
Internal RAM	5 s pre-alarm recording
Memory card slot	Supports up to 32 GB microSDHC / 2 TB microSDXC card. (A memory card of Class 6 or higher is recommended for HD recording)
Recording	Continuous recording, ring recording, alarm/ events/schedule recording
Input/output	
Analog video out	CVBS (NTSC), 1 Vpp, SMB, 75 Ohm (surge protected)
Audio connectors	3.5 mm stereo jack (x2)
Audio line in	12 kOhm typical, 1 Vrms max
Audio line out	1 Vrms at 1.5 kOhm typical,
Alarm input connectors	Clamp (x2 non-isolated closing contact)
Alarm input activation voltage	+5 VDC to +40 VDC (+3.3 VDC with DC-coupled 22 kOhm pull-up resistor)
Alarm output connector	Clamp
Alarm output voltage	30 VAC or +40 VDC Maximum 0.5 A continuous, 10VA
Ethernet	RJ45
Data port	RS-232/422/485
Audio streaming	
Standard	G.711, 8 kHz sampling rate L16, 16 kHz sampling rate AAC-LC, 48 kbps at 16 kHz sampling rate AAC-LC, 80 kbps at 16 kHz sampling rate
Signal-to-Noise Ratio	>50 dB
Audio Streaming	Full-duplex / half duplex
Software	
Unit discovery	IP Helper
Unit configuration	Via web browser or Configuration Manager
Firmware update	Remotely programmable
Software viewing	Web browser; Video Security Client; Video Security App; Bosch Video Management System; Bosch Video Client; or third party software
Latest firmware and software	http://downloadstore.boschsecurity.com/

Network	
Protocols	IPv4, IPv6, UDP, TCP, HTTP, HTTPS, RTP/RTCP, IGMP V2/V3, ICMP, ICMPv6, RTSP, FTP, Telnet, ARP, DHCP, APIPA (Auto-IP, link local address), NTP (SNTP), SNMP (V1, MIB-II), 802.1x, DNS, DNSv6, DDNS (DynDNS.org, selfHOST.de, no-ip.com), SMTP, iSCSI, UPnP (SSDP), DiffServ (QoS), LLDP, SOAP, Dropbox, CHAP, digest authentication
Encryption	TLS 1.2, SSL
Ethernet	10/100 Base-T, auto-sensing, half/full duplex
Connectivity	Auto-MDIX
Interoperability	ONVIF Profile S; ONVIF Profile G; GB/T 28181

Mechanical	
Dimensions (H x W x L)	141 x 164 x 430 mm (5.6 x 6.5 x 16.9 in.) including sunshield
Weight	<3.5 kg (7.72 lb)
Construction	Aluminum casing, silicone gaskets
Color	RAL 9003 White
Window	Germanium glass (Ø52 x 3 mm)

Environmental	
Operating temperature	-50°C to +55°C (-58°F to +131°F) for continuous operation;
Storage temperature	-55°C to +70°C (-67°F to +158°F)
Operating Humidity	5% to 95% RH non-condensing
Storage Humidity	up to 98% RH
Ingress protection	IP66, NEMA-4X
Enclosure protection	Wind load 150 mph; NEMA TS2 vibration, shock

Ordering information

NHT-8000-F07QS DINION THERMAL, <9Hz, QVGA, 7.5mm

Thermal imaging IP camera
QVGA
9 fps
7.5 mm lens
Order number **NHT-8000-F07QS**

NHT-8000-F07QF DINION THERMAL, 60Hz, QVGA, 7.5mm

Thermal imaging IP camera
QVGA
60 fps
7.5 mm lens
Order number **NHT-8000-F07QF**

NHT-8000-F19QS DINION THERMAL, <9Hz, QVGA,19mm

Thermal imaging IP camera
QVGA
9 fps
19 mm lens
Order number **NHT-8000-F19QS**

NHT-8000-F19QF DINION THERMAL, 60Hz, QVGA,19mm

Thermal imaging IP camera
QVGA
60 fps
19 mm lens
Order number **NHT-8000-F19QF**

NHT-8001-F09VS DINION THERMAL, <9Hz, VGA,9mm

Thermal imaging IP camera
VGA
9 fps
9 mm lens
Order number **NHT-8001-F09VS**

NHT-8001-F09VF DINION THERMAL, 30Hz, VGA, 9mm

Thermal imaging IP camera
VGA
30 fps
9 mm lens
Order number **NHT-8001-F09VF**

NHT-8001-F17VS DINION THERMAL, <9Hz, VGA, 16.7mm

Thermal imaging IP camera
VGA
9 fps
16.7 mm lens
Order number **NHT-8001-F17VS**

NHT-8001-F17VF DINION THERMAL, 30Hz, VGA, 16.7mm

Thermal imaging IP camera
VGA
30 fps
16.7 mm lens
Order number **NHT-8001-F17VF**

NHT-8001-F35VS DINION THERMAL, <9Hz, VGA, 35mm

Thermal imaging IP camera
VGA
9 fps
35 mm lens
Order number **NHT-8001-F35VS**

NHT-8001-F35VF DINION THERMAL, 30Hz, VGA, 35mm

Thermal imaging IP camera
VGA
30 fps
35 mm lens
Order number **NHT-8001-F35VF**

NHT-8001-F65VS DINION THERMAL, <9Hz, VGA, 65mm

Thermal imaging IP camera
VGA
9 fps
65 mm lens
Order number **NHT-8001-F65VS**

NHT-8001-F65VF DINION THERMAL, 30Hz, VGA, 65mm

Thermal imaging IP camera

VGA

30 fps

65 mm lens

Order number **NHT-8001-F65VF**

Accessories

NHA-U-WMT Bracket housing for DINION thermal 8000

Universal Wall Mount Bracket

Order number **NHA-U-WMT**

NDA-U-PMAL Pole mount adapter large

Universal pole mount adapter, white; large

Order number **NDA-U-PMAL**

NDA-U-CMT Corner mount adapter

Universal corner mount, white

Order number **NDA-U-CMT**

Represented by:

Europe, Middle East, Africa:
Bosch Security Systems B.V.
P.O. Box 80002
5600 JB Eindhoven, The Netherlands
Phone: + 31 40 2577 284
emea.securitysystems@bosch.com
emea.boschsecurity.com

Germany:
Bosch Sicherheitssysteme GmbH
Robert-Bosch-Ring 5
85630 Grasbrunn
Germany
www.boschsecurity.com

North America:
Bosch Security Systems, Inc.
130 Perinton Parkway
Fairport, New York, 14450, USA
Phone: +1 800 289 0096
Fax: +1 585 223 9180
onlinehelp@us.bosch.com
www.boschsecurity.us

Asia-Pacific:
Robert Bosch (SEA) Pte Ltd, Security Systems
11 Bishan Street 21
Singapore 573943
Phone: +65 6571 2808
Fax: +65 6571 2699
apr.securitysystems@bosch.com
www.boschsecurity.asia