



Gunnebo PasSec

Automated Anti-Return Gate

The PasSec anti-return gate is designed for airports, and also suitable for ferry terminals, ports, railways or any mass transit location where there is a need to direct passenger flow in one direction.

Located ideally after Immigration control and before baggage reclaim to prevent passengers attempting to return back to airside, or after customs and before the open landside area, to prevent unauthorized access to the baggage claim and to duty-free areas by the general public.

PasSec is available in two different standard models: a single door (PasSec S) and a high security version with

double doors and interlock corridor (PasSec HS). Both versions share a unique, elegant and minimalist design.

Combining different technologies to achieve state of the art performances, PasSec passage detection algorithms constantly monitor the flow of persons through the monitored area until they exit, preventing attempts of access in the wrong direction or turn around inside the mantrap.

Local and remote connectivity allows advanced gate managing and control. The PasSec design has been optimized for easy maintenance and simplified installation, not requiring any accessibility from the topside of the roof.

Technical Specifications

Drive

High reliability DC motor with integrated reduction gearbox and electro mechanic brake.

Materials

- Casework: brushed AISI304 Stainless Steel and anodized aluminum
- Moving panels: 10mm security tempered glass
- Side panels: 10mm security tempered glass

Fast closing barriers option

FCB (Fast Closing Barriers) additional motorized obstacles are provided on S version, and optionally on HS, both inside the corridor and at exit (land side).

Operational Modes

By key selector positioned externally on entry arch, the PasSec can be operated in four modes:

- **Automatic:** Unidirectional in the exit direction only
- **Interlocking:** Unidirectional secure controlled passage (HS only)
- **Maintenance:** for routine maintenance under safe conditions
- **Cleaning:** for safe routine cleaning operations

When key selector is in automatic mode, PasSec can accept remote operational mode settings from remote connection.

The four modes can be re-configured based on specific requirements.

Passage Sensors

Different sensors analyze the movement of passengers, detect the direction, position of travel and activate the doors and alarms accordingly. Should a passenger walking in the reverse direction be detected, the doors will close and local/remote alarms generated.

- PIR (Passive Infrared Sensor) detect persons approaching the gate in entry to automatically open the doors (S and HS)
- A first 3D camera inside the corridor detects when a person turns back after crossing a “virtual threshold line” (HS only)
- A second 3D camera positioned in exit area detects passengers trying to walk through the gate in the forbidden direction or turning around (S and HS)

Controlling Unit

Gunnebo Zuul modular electronic platform

User Interface

- TCP/IP advanced remote connectivity
- SDK for easy interface implementation
- RS232 low level ModBus option
- Configuration and diagnostics tool (Windows 10/11)
- Configurable digital I/O
- Configurable audio messages on SD card

Technical Data

Power Supply	115/230Vac 50/60Hz
Power Rating	600VA peak / 100VA standby
Operating temperature	5°C to 45°C 95% RH non-condensing
Flow Rates	50 to 100 passages per minute depending upon passenger speed of travel and selected mode

Advanced Features

- TCP/IP advanced remote connectivity
- SDK for easy interface implementation
- RS232 low level ModBus option
- Configuration and diagnostics tool (Windows 10/11)
- Configurable digital I/O
- Configurable audio messages on SD card
- White LED ambient illumination
- Configurable audio messages
- Left items detection

Optional Features

- RGB animated lights on left and side bottom rails (S and HS)
- Thrown object detection (HS)
- Non-standard passage widths and corridor lengths on request

The PasSec S and HS Range

PasSec S



The PasSec S features a single set of doors in archway with one set of fast closing barriers at exit as standard.

PasSec HS0



The PasSec HS0 features a double set of doors in an archway.

PasSec HS1



The PasSec HS1 features a double set of doors in an archway with one set of fast closing barriers located at exit.

PasSec HS2



The PasSec HS2 features a double set of doors in an archway with two sets of fast closing barriers - one set located between the two main doors and one set at the exit.

Alarm Conditions

Alarm triggered in case of door obstruction, wrong way/turnback scenarios, left items, thrown items and system diagnostic failure.

Configurations

- 950 and 1200mm clear walkways options
- FCBs (Fast Closing Barriers) configured as follows:
 - **S version**: single arch and one FCB at exit
 - **HS0**: two arches and interlock corridor, no FCBs
 - **HS1**: two arches and interlock corridor, one FCB at exit
 - **HS2**: two arches and interlock corridor, two FCBs, on inside the corridor, one at exit
- Single and multiple lanes configurations

Benefits

- Reduction in staffing costs
- Superior anti-return detection
- Increased security
- Unobtrusive design combined with highly glazed aesthetic
- High visibility of traveler progress

Applications

- Airports
- Seaports and Ferry terminals
- Museums

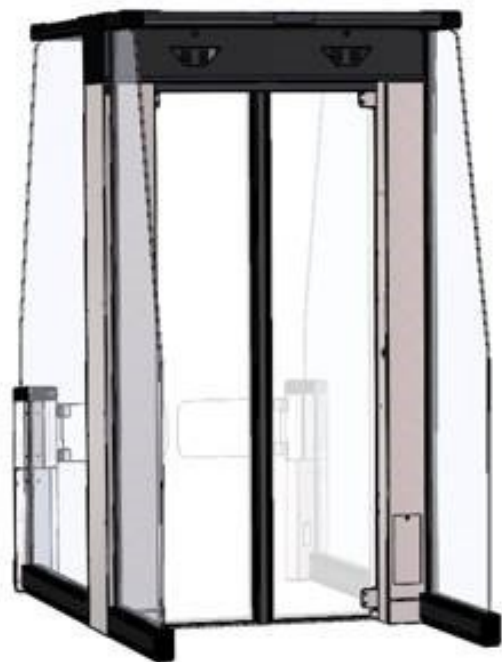

Site Preparation

PasSec HS standard width

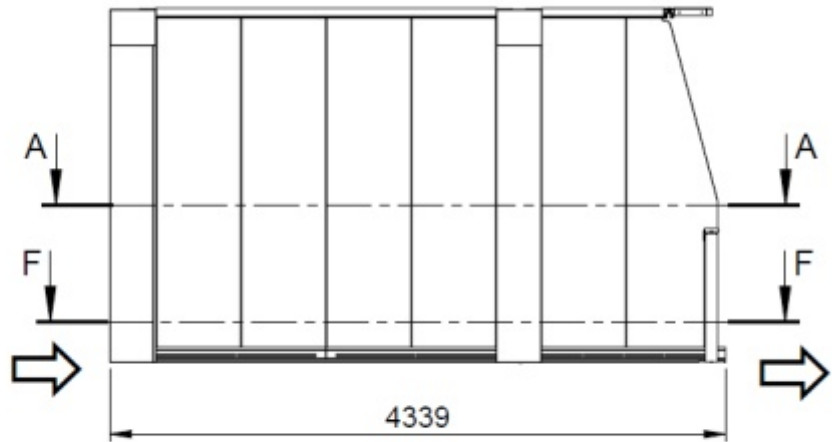
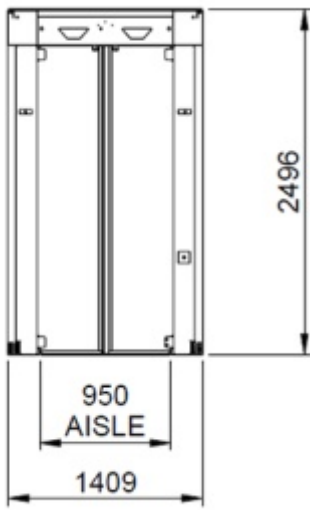

PasSec HS wide version



Please note: this is an example of one possible implementation. Some dimensions can vary according to requirements.

Concrete Base to specification at least (cube) 300N/mm² of resistance. Base to be flat and level to +/- 5mm over footprint area.

PasSec S standard width

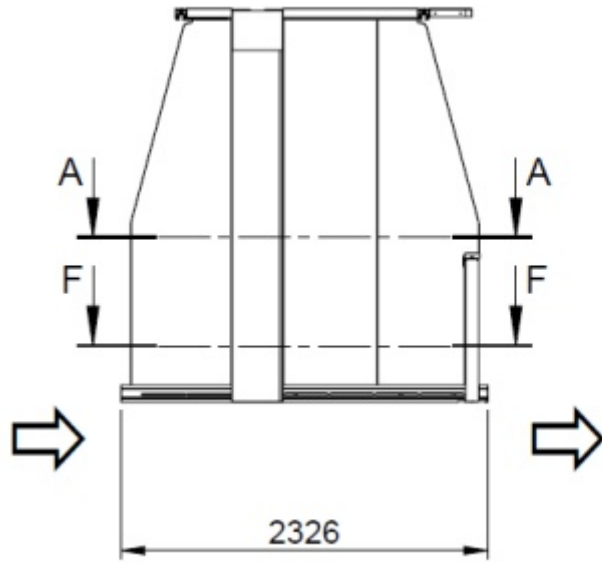
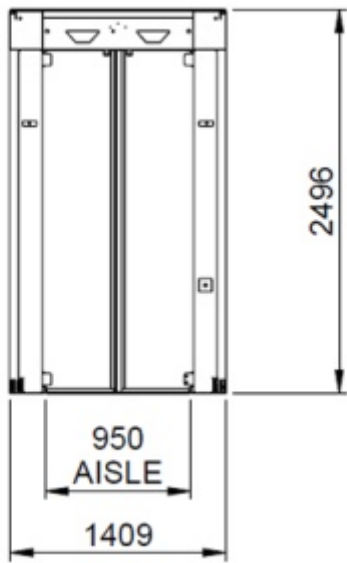

PasSec S wide version

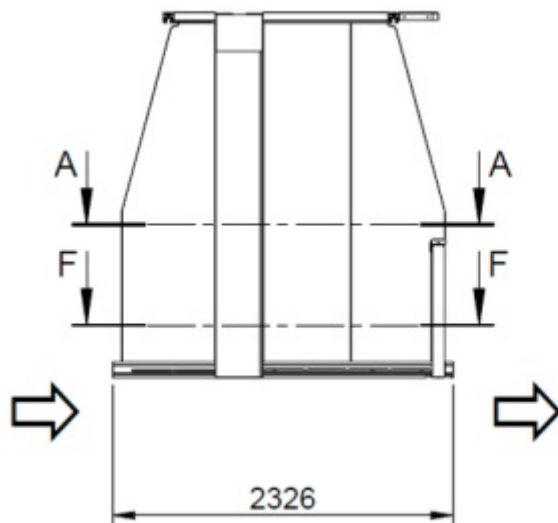
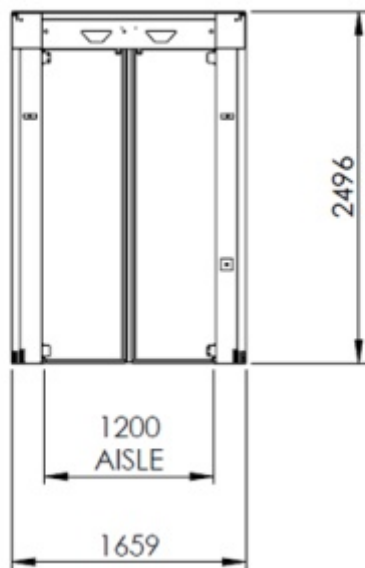

Want to see the PasSec in full action?
Scan this QR code with your smartphone.

Gunnebo PasSec



International Standards

CE Compliance meeting the following directives:

- 2006/42/EC Machine Directive
- 2014/35/EU Low Voltage Directive
- 2014/30/EU EMC Directive

Norms

- EN 61000-6-3 (2007) Electromagnetic Compatibility – generic standard, emissions
- EN 61000-6-2 (2007) Electromagnetic Compatibility – generic standard, immunity
- EN60335-1 (2012) + EN60335-1/A11 (2014) Household and similar electrical appliances. Safety. General requirements
- EN16005 Power operated pedestrian doorsets – Safety in use – Requirements and test methods
- Safety system ISO EN13849 performance level C

Gunnebo Entrance Control Ltd
The Gate House
Ashdown Business Park
Michael Way
Maresfield
East Sussex
TN22 2DU
United Kingdom

T: +44 (0)1825 761 022
E: info.entrancecontrol@gunnebo.com



Learn more about our full range of airport security solutions

GUNNEBO®

Gunnebo PasSec



Take advantage of our knowledge:
blog.gunneboentrancecontrol.com or
www.gunneboentrancecontrol.com

